

BUILDING ENVELOPE

NOTE

FOR FULL LOT & EASEMENT DIMENSIONS REFER TO SHEET 6 ON PS905668T.

Date: 28 September 2022
Dwg: 329005-ST52-BD



VERIS AUSTRALIA PTY LTD
A | Level 3, 1 Southbank Blvd
Southbank VIC 3006
T | +61 3 7019 8400
E | melbourne@veris.com.au
W | www.veris.com.au

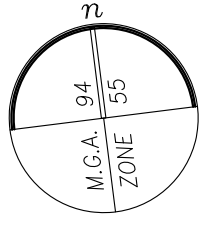
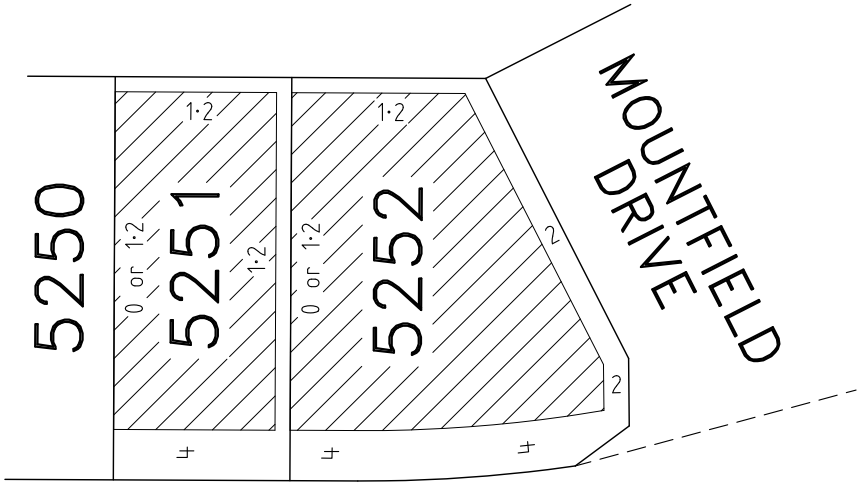

ERROL BOULEVARD

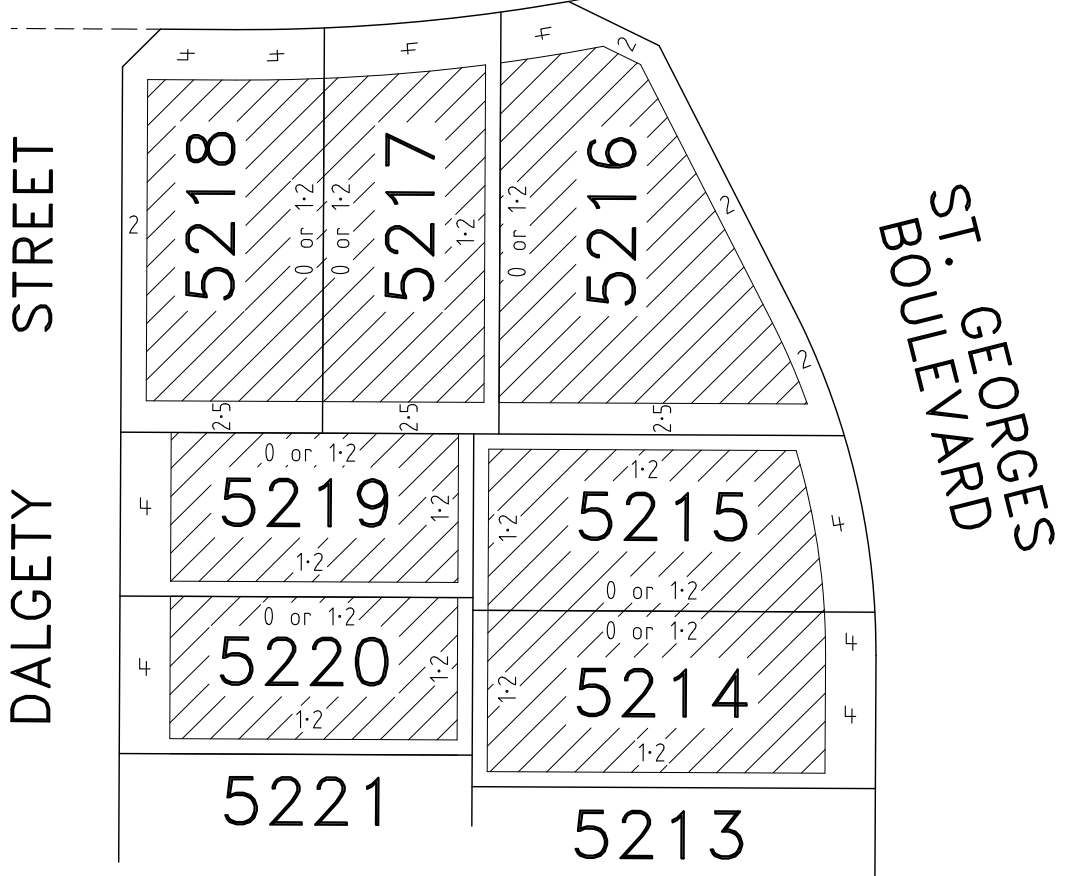

 BUILDING ENVELOPE

NOTE
FOR FULL LOT & EASEMENT DIMENSIONS REFER TO SHEETS 4 & 5 ON PS905668T.

Date: 28 September 2022
Dwg: 329005-ST52-BD

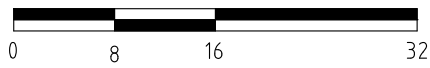

VERIS AUSTRALIA PTY LTD
A | Level 3, 1 Southbank Blvd
Southbank VIC 3006
T | +61 3 7019 8400
E | melbourne@veris.com.au
W | www.veris.com.au

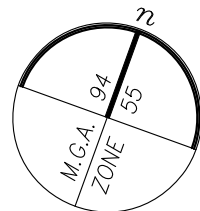

MOUNTFIELD DRIVE

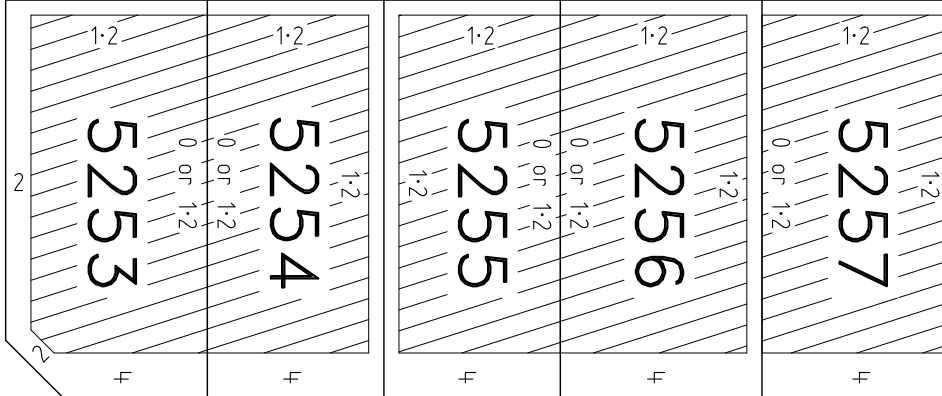

ERROL BOULEVARD

ST. GEORGES BOULEVARD

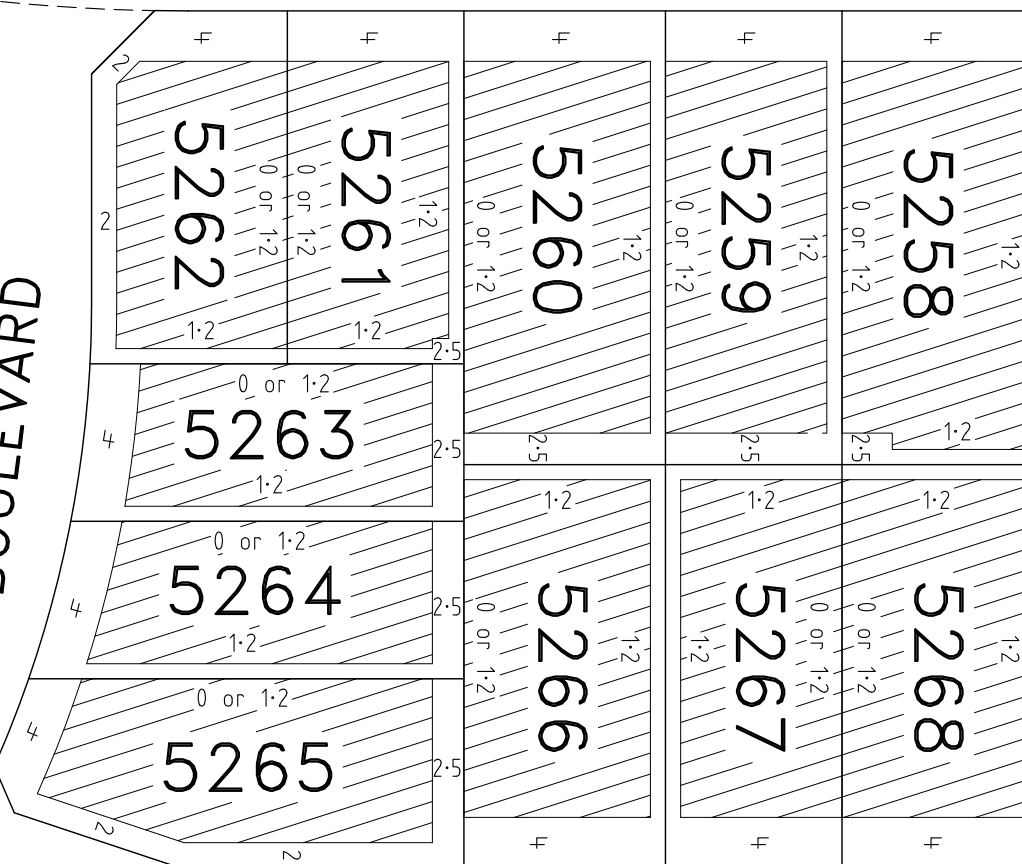

BONANZA STREET



BUILDING ENVELOPE

THE BUILDING ENVELOPES OF LOTS 5258 & 5261 ARE PARTIALLY DEFINED BY EASEMENT BOUNDARIES.

NOTE

FOR FULL LOT & EASEMENT DIMENSIONS REFER TO SHEETS 4 & 5 ON PS905668T.

Date: 28 September 2022
Dwg: 329005-ST52-BD

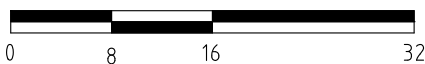

VERIS AUSTRALIA PTY LTD
A | Level 3, 1 Southbank Blvd
Southbank VIC 3006
T | +61 3 7019 8400
E | melbourne@veris.com.au
W | www.veris.com.au

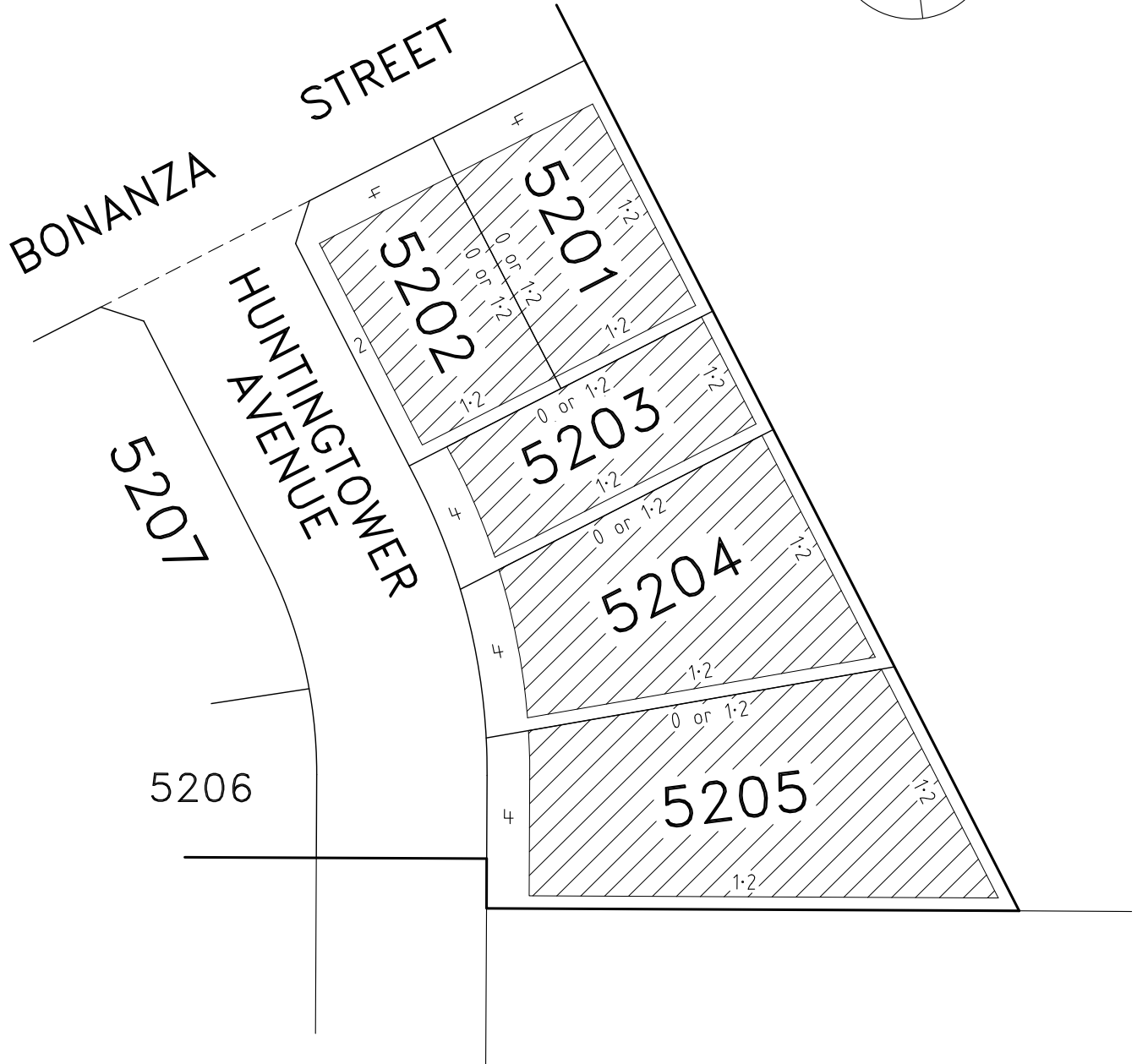
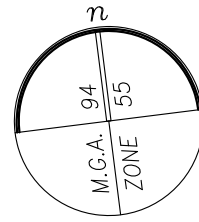

BUILDING ENVELOPE

NOTE

FOR FULL LOT & EASEMENT DIMENSIONS REFER TO SHEET 4 ON PS905668T.

Date: 28 September 2022
Dwg: 329005-ST52-BD

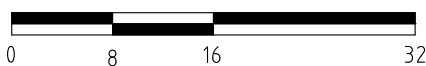

veris

VERIS AUSTRALIA PTY LTD
A | Level 3, 1 Southbank Blvd
Southbank VIC 3006
T | +61 3 7019 8400
E | melbourne@veris.com.au
W | www.veris.com.au

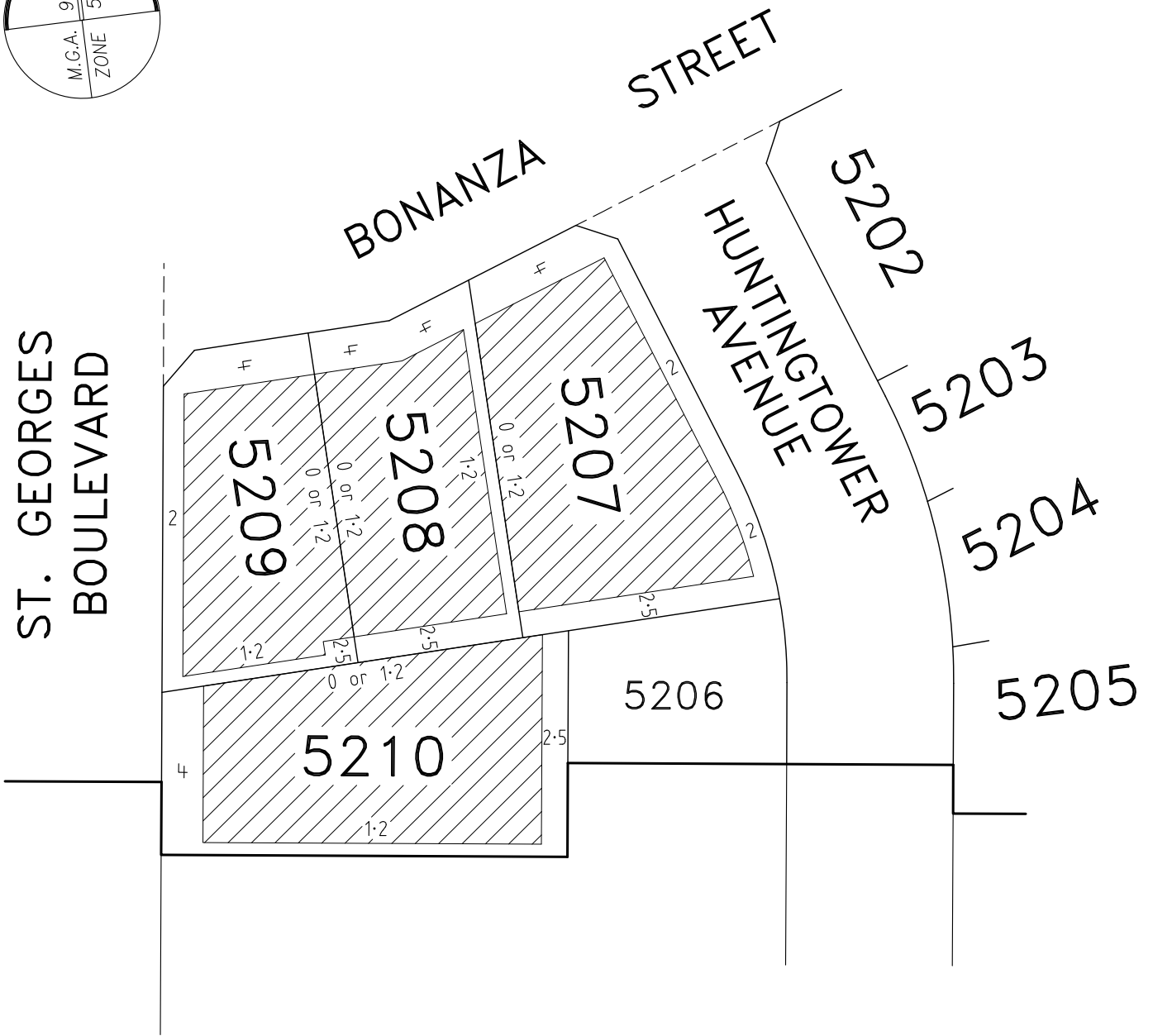
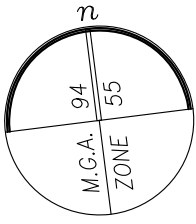

 BUILDING ENVELOPE

THE BUILDING ENVELOPE OF LOT 5209 IS PARTIALLY DEFINED BY EASEMENT BOUNDARIES.

NOTE

FOR FULL LOT & EASEMENT DIMENSIONS REFER TO SHEET 4 ON PS905668T.

Date: 28 September 2022
Dwg: 329005-ST52-BD

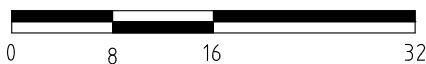

VERIS AUSTRALIA PTY LTD
A | Level 3, 1 Southbank Blvd
Southbank VIC 3006
T | +61 3 7019 8400
E | melbourne@veris.com.au
W | www.veris.com.au

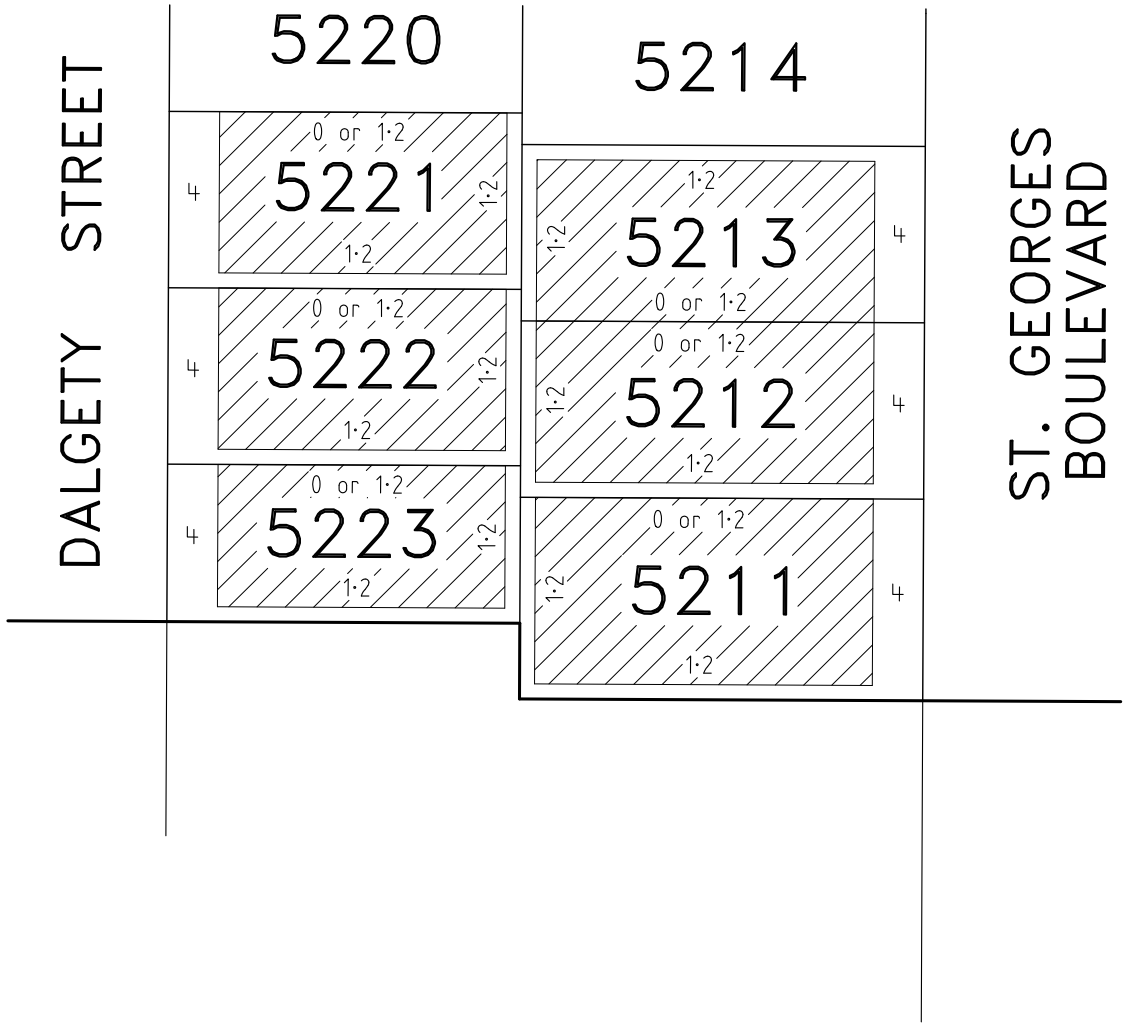
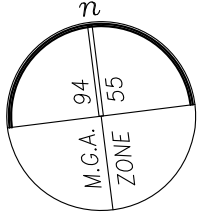

BUILDING ENVELOPE

NOTE

FOR FULL LOT & EASEMENT DIMENSIONS REFER TO SHEET 4 ON PS905668T.

Date: 28 September 2022
Dwg: 329005-ST52-BD

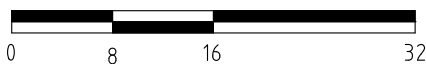

VERIS AUSTRALIA PTY LTD
A | Level 3, 1 Southbank Blvd
Southbank VIC 3006
T | +61 3 7019 8400
E | melbourne@veris.com.au
W | www.veris.com.au

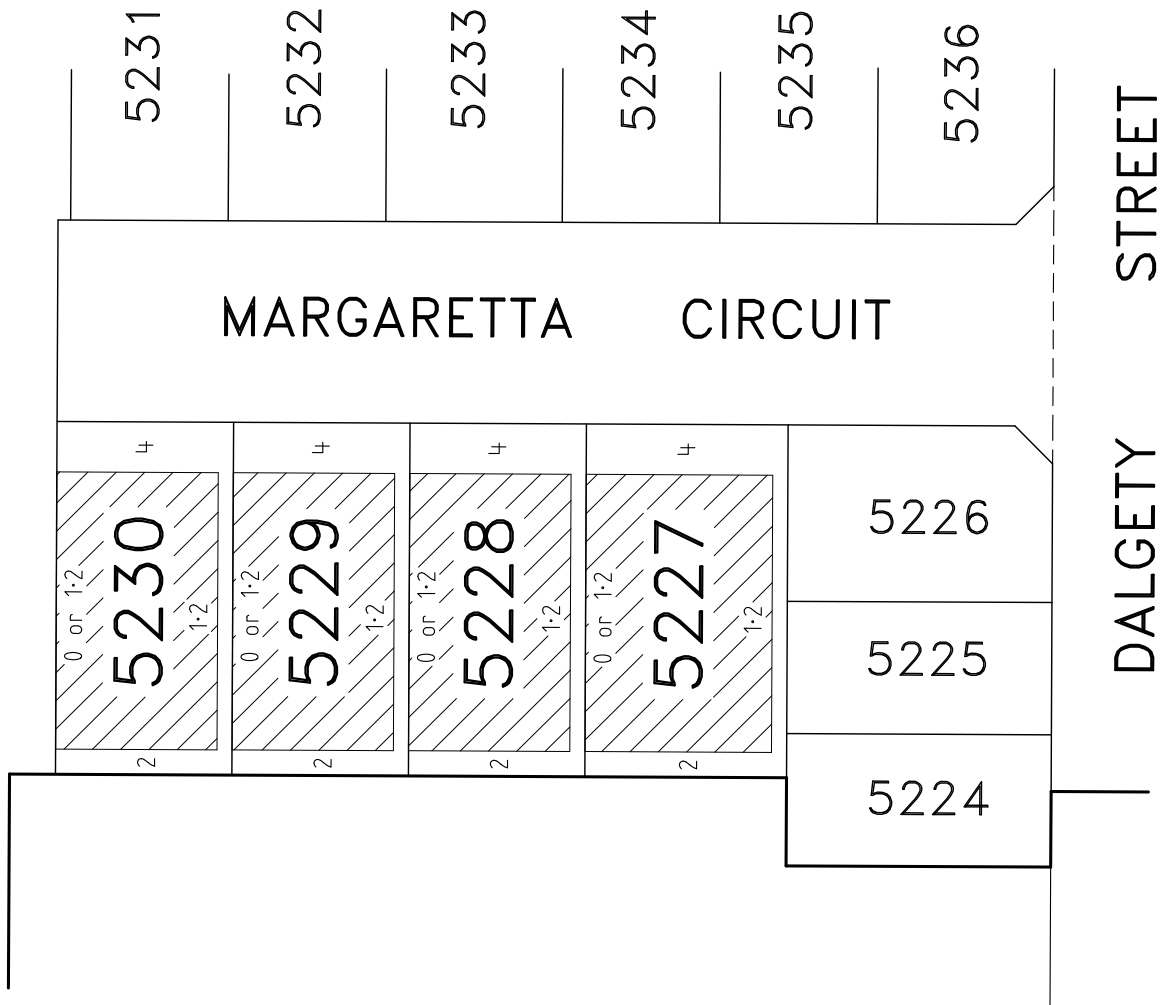
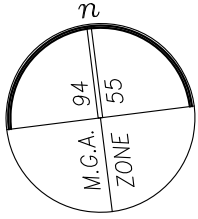

BUILDING ENVELOPE

NOTE

FOR FULL LOT & EASEMENT DIMENSIONS REFER TO SHEET 6 ON PS905668T.

Date: 28 September 2022
Dwg: 329005-ST52-BD

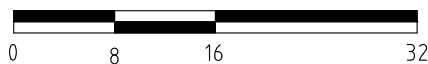

VERIS AUSTRALIA PTY LTD
A | Level 3, 1 Southbank Blvd
Southbank VIC 3006
T | +61 3 7019 8400
E | melbourne@veris.com.au
W | www.veris.com.au